



// ONE BRAND // ONE SOURCE // ONE SYSTEM



// SERVICE // MATERIAL PROCESSING // SURFACE PROTECTION // AUTOMOTIVE

REMACLEAN

Belt cleaning systems



REMA TIP TOP

We have been an expert partner you can rely on for over 50 years. REMA TIP TOP offers you sophisticated technical and economical solutions to problems in the areas of:

- Conveyor and Processing Systems
- Surface Protection
- OTR/EMTyre Repair and Service.

We specialize in ensuring your industrial systems are always ready and operating to their maximum.

For you, this means:

- longer service life
- reduced downtime
- optimized operational safety
- increased production capacity and higher profits.

We advise. We deliver. We install. We support.

The brand name REMA TIP TOP stands for a comprehensive network of expert knowledge and skills:

- You benefit from a differentiated range of products that are constantly setting new standards when it comes to quality.
- You can rely on the optimum all-round service provided by our team of highly qualified specialists
- And you can access our unique global sales and service network of experienced, established partners. **Anytime.**

- Subsidiary companies from REMA TIP TOP AG
- Agencies from REMA TIP TOP AG

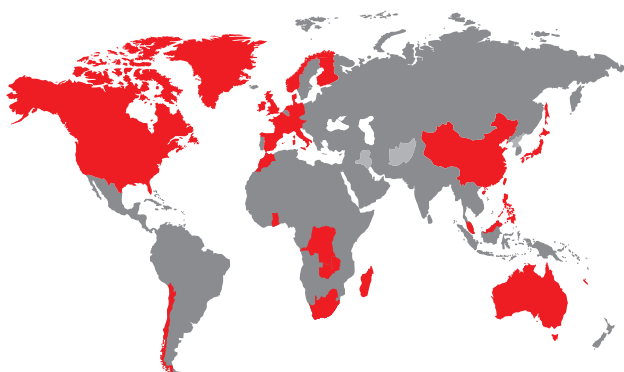

CONTENT

REMA TIP TOP - Your capable partner for conveyor belt cleaning	3
Scraper rubber	4
REMACLEAN 60 und 70	4
REMACLEAN CAB	4
Scraper bars	5
REMACLEAN KWA	5
REMACLEAN PUR	5
REMACLEAN C	6
REMACLEAN M	6
Tension units	7
STANDARD	7
PRECISION	7
INNOVATION	7
REMACLEAN F-Series – Primary belt cleaning systems	8
REMACLEAN HM-F1	8
REMACLEAN HM-F2	8
REMACLEAN PUR-F3 / PUR-F4	9
REMACLEAN PUR-F5	9
REMACLEAN U-Series – Belt cleaning systems for return side application	10
REMACLEAN HM-U1	10
REMACLEAN HM-U2	10
REMACLEAN HM-U3	11
REMACLEAN HM-U4/HM-U5	11
REMACLEAN HM-U6	12
REMACLEAN HM-U7 / HM-U8	12
REMACLEAN HM-U9	13
REMACLEAN HM-U10	13
REMACLEAN HM-U11 R	14
Belt cleaning brushes	14
REMACLEAN GRB	14
REMACLEAN TMB	15
REMACLEAN SGB	15
Internal belt cleaning systems	16
REMACLEAN RB-IGD – Diagonal scraper	16
REMACLEAN RB-IGP – V-Plough scraper	16
Overview: Which system for which application?	17
F-Series	17
U-Series	18
Scraper bars	20
Belt cleaning brushes	21
Inner Belt Scraper Systems	22
Questionnaire: REMACLEAN Belt Cleaning System	23

REMA TIP TOP – Your capable partner for conveyor belt cleaning



Increase your productivity – with REMACLEAN conveyor belt cleaning systems from REMATIP TOP!

The cleaning of conveyor belts is a subject that is often neglected by many plant operators. Optimal cleaning, however, contributes to the economic operation of the plant, because interruptions to production process caused by contamination can lead to inefficiency and even to the entire conveying system coming to a halt. In addition, inadequate cleaning of the belt brings additional cost, for example through increased wear on pulleys or belt, loss of bulk material and expenses for manual cleaning-up work.

Reductions in plant availability and maintenance costs that can be avoided are no longer acceptable to operators.

The demands placed on the manufacturers of conveyor belt cleaning systems are therefore clearly formulated:

- Optimum cleaning results while at the same time protecting the belt
- Efficient installation and servicing
- A long service life of the belt cleaning system

Conveyor belt cleaning is a complex matter. Several factors must be simultaneously taken into

account in order to achieve good and economical cleaning results:

- Selection of a suitable belt cleaning system for the particular application
- Combination of the right systems (pre- and fine cleaning)
- Optimum position of the belt cleaners in the conveyor system
- Installation by trained technicians
- Determination and execution of regular servicing activities by trained technicians

If any one of these points is not taken into account even the best system will fail after a short time and therefore will not contribute to economic operation.

REMA TIP TOP is your competent partner for the choices, installation and servicing of belt cleaning systems – and much more. REMA TIP TOP has suitable products and services for all areas of belt conveyors. Our experienced specialists advise on, develop and optimize your conveying systems. Our dense service network guarantees the availability of trained technicians – anytime.

Our modern training center for conveyor belt systems in Nauen, near Berlin, has both seminar rooms for the teaching of theoretical knowledge and models for practical training (installation, servicing, etc.).

SCRAPER RUBBER

REMACLEAN 60 and 70

Due to its excellent abrasion-resistance and high elasticity, our special rubber materials REMACLEAN 60 and REMACLEAN 70 are perfectly suitable and achieve significantly longer service life compared to conventional rubber materials. The scraper rubber is mounted on the system's existing scraper system and when new may protrude from the bracket by up to its own thickness.



Product	REMACLEAN 60	REMACLEAN 70	REMACLEAN 70 V*
Hardness [± 5 Shore A]	60	62	60
Abrasion [mm ³]	90	55	180
Available dimensions [Roll length 10 m]	Thickness: 5/7/8/10/15/20/30 mm Width: 100/120/150/200/250/2000 mm	Thickness: 5/7/10/15/20/30 mm Width: 100/120/150/200/2000 mm	Thickness: 8/10/15/20/30 mm Width: 100/120/150/200/2000 mm

* German underground approval: LOBA No. 18.43.21-91-4 Polish underground approval: DopuszczenieWUG Katowice No. B/1724/2007 May be used in ATEX installations.

REMACLEAN CAB

REMACLEAN CAB consists of three layers with different Shore hardnesses: two hard outer layers surround a soft core. This combination allows intensive and yet protective conveyor belt cleaning. At the same pressure against the conveyor belt, the cleaning effect of REMACLEAN CAB is approximately 20 % better than standard qualities. Service life is often several times longer than that of conventional scraper rubber materials. REMACLEAN CAB is mounted on the existing scraping system of the equipment and when new can protrude from the bracket by more than one and a half times its own thickness.

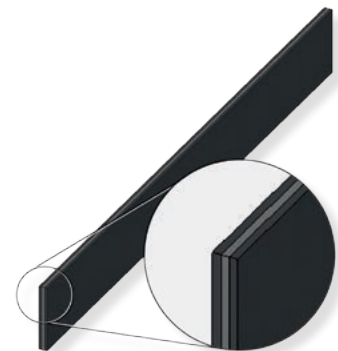

Product	REMACLEAN CAB green	REMACLEAN CAB gray	REMACLEAN CAB V*
Hardness [± 5 Shore A]	70 / 48 / 70	85 / 50 / 85	73 / 60 / 73
Abrasion [mm ³]	90 / 190 / 90	140 / 130 / 140	120 / 130 / 120
Available dimensions [Roll length 10 m]	Thickness: 15/20/25/30/40/50 mm Width: 100/120/150/200/250/2000 mm	Thickness: 15/20/25/30/40/50 mm Width: 100/120/150/200/250/2000 mm	Thickness: 15/20/25/30/40/50 mm Width: 100/120/150/200/250/2000 mm

* German underground approval: LOBA No. 18.43.21-91-4/18.43.21-30-33 Polish underground approval: DopuszczenieWUG Katowice No. B/1724/2007 May be used in ATEX installations.

SCRAPER BARS

REMA TIP TOP offers a wide range of scraper bars for cleaning of conveyor belt top covers on the return side of the conveyor. Scraper bars made of rubber, polyurethane, rubber-ceramic and rubber-metal are available.

REMACLEAN KWA

Benefits and features:

- Three scraper bars which can be used one after the other
- Belt-friendly scraper with good cleaning efficiency
- Long service life due to highly abrasion resistant rubber material
- Cost-effective due to excellent price-performance ratio
- Installation is recommended with REMA TIP TOP tension units INNOVATION, PRECISION or STANDARD
- For belt speeds up to 3.5 m/s

Product	REMACLEAN KWA	REMACLEAN KWA V*
Hardness [± 5 Shore A]	64	62
Abrasion [mm ³]	50	130
Belt width [mm]	500-1800	500-1400
Features	Highly abrasion resistant	Self-extinguishing, anti-static and moderate oil resistant



*German underground approval: LOBA No. 18.43.21-91-24
Polish underground approval: Dopuszczenie WUG Katowice No. B/1724/2007

REMACLEAN PUR

Benefits and features

- Two scraper bars which can be used one after the other
- Long service life of REMATHAN polyurethane (90 ±5 Shore A)
- Oil and grease resistant
- For belt widths 500 - 1600 mm
- Installation is recommended with REMA TIP TOP tension units INNOVATION, PRECISION or STANDARD
- Suitable for use with mechanical fasteners
- Suitable for shuttle belt operation in combination with tension unit INNOVATION
- For belt speeds up to 3.5 m/s

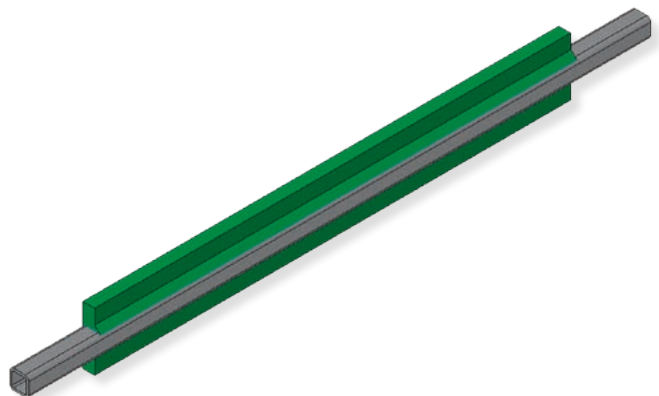

SCRAPER BARS

REMACLEAN C

Benefits and features

- Highly wear resistant through AL_2O_3 ceramic material
- Flexibility through ceramic material embedded in rubber
- Belt friendly cleaning due to rounded outer ceramic elements
- For belt widths 400 - 1600 mm
- Installation is recommended with REMA TIP TOP tension units INNOVATION, PRECISION or STANDARD
- Do not use with quartz-containing bulk material
- For belt speeds up to 3.5 m/s

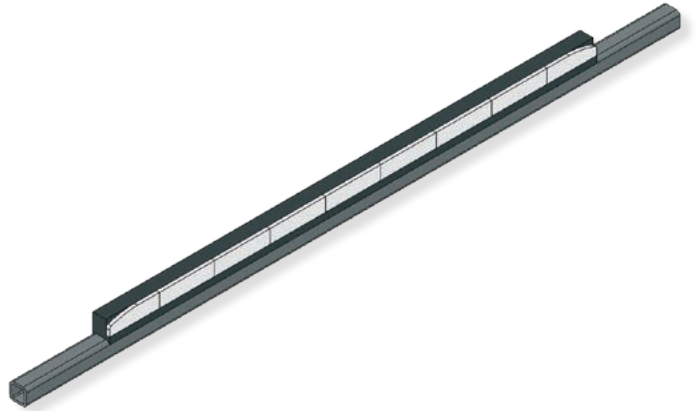

REMACLEAN M

Benefits and features

- Highly wear-resistant through tungsten carbide insert
- Permanently vulcanised into an elastic rubber base
- Belt friendly cleaning through rounded outer tungsten carbide blades
- For belt widths 400 - 1600 mm
- Installation is recommended with REMA TIP TOP tension units INNOVATION, PRECISION or STANDARD
- For belt speeds up to 3.5 m/s



TENSION UNITS

STANDARD

- Extremely long service life
- Vibration absorbing and flexible due to integrated rubber spring elements
- Quick and easy replacement of scraper systems
- Consistent cleaning performance due to constant contact pressure
- Can be retrofitted to all belt conveyors with minimum effort
- Low overall height
- Maintenance-free; minimum time required for inspection and servicing
- For belt widths 400 - 1600 mm
- STANDARD INOX for belt widths of 400 - 900 mm (stainless steel version)

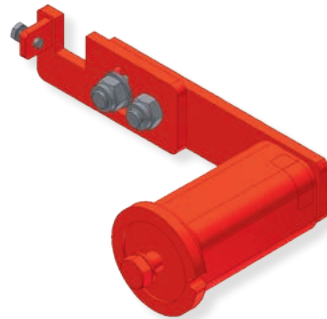

PRECISION

Same features as STANDARD and additional:

- Protection against damage to the conveyor belt if the scraper is worn out
- Adjustable pitch of scraper blade
- Pivoting mechanism for precise 90° adjustment of scraper to belt
- Scale for setting the contact pressure
- For belt widths 400 - 1800 mm

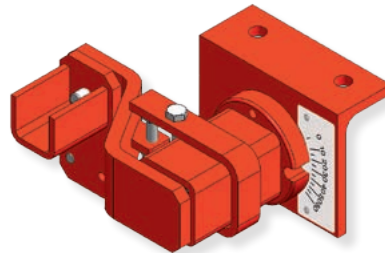

INNOVATION

Same features as PRECISION and additional:

- Contact pressure continuously adjustable by tension spindle
- Pressure adjustment by one person
- Precise micro adjustment of contact pressure
- Can be adjusted without heavy tools
- Suitable for shuttle belt operation in combination with REMACLEAN PUR and HML scrapers
- Pivoting mechanism for precise 90° adjustment of scraper to belt
- Universal installation possibilities
- Display for adjustment of contact pressure
- For belt widths 400 - 1800 mm



REMACLEAN F-SERIES – for use on pulley

The belt cleaning systems of the REMA TIP TOP F Series are designed for belt cleaning at the head pulley. Systems with tungsten carbide blades or scraper blades made of polyurethane are available.

REMACLEAN HM-F1

Belt scraper system with individual elastically supported tungsten carbide blades and a spindle-type tension unit for cleaning of conveyor belt top covers at the head pulley (pulley diameters up to 2000 mm).

- Universally applicable for many types of materials
- High cleaning efficiency due to optimum adaptability of the blades (each one elastically supported) to the conveyor belt surface
- Long service life due to highly wear resistant materials and anti-caking skirts
- Easy installation below pulley axis (outside of main material flow)
- Low maintenance tensioning by rubber spring elements
- Open design of segments to ensure material run off
- Tension unit can be mounted inside or outside the conveyor construction
- Suited for reverse operation
- For belt speeds up to 6.5 m/s

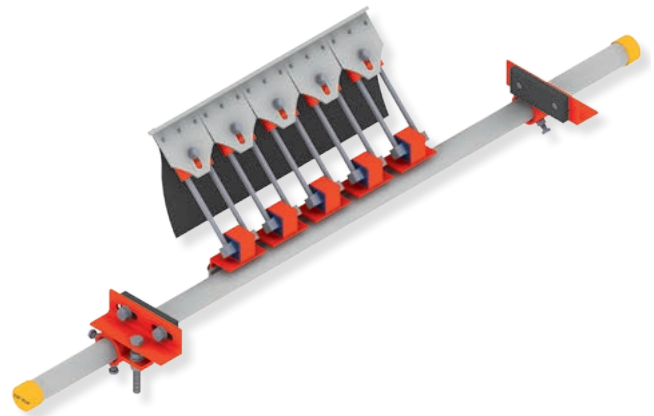

REMACLEAN HM-F2

Belt scraper system with individual elastically supported tungsten carbide blades and a spindle-type tension unit for cleaning of conveyor belt top covers at the head pulley (pulley diameters up to 1200 mm).

- High cleaning efficiency due to optimum adaptability of the blades (individual bearings) to the conveyor belt surface
- Long service life due to highly wear resistant materials
- Installation below pulley axis (outside of main material flow)
- Open design of segments to ensure material run off
- Easily adjustable, low maintenance through rubber spring elements
- Constant and ideal contact pressure; easily adjustable and display readable
- Tension unit can also be mounted outside the conveyor construction
- Suited for reverse operation
- For belt speeds up to 4.5 m/s (for belt widths 1600 and more up to 2.5 m/s)

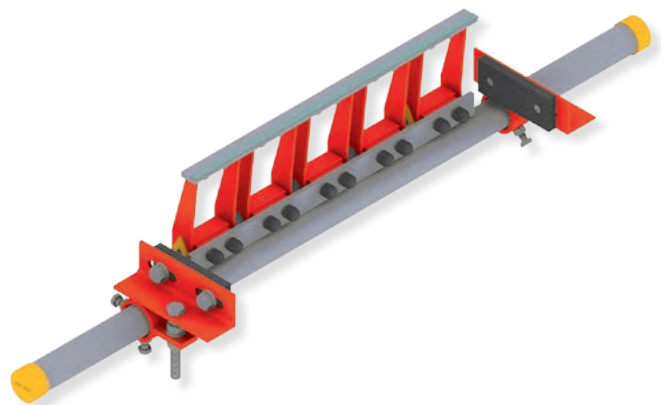

REMACLEAN F-SERIES – for use on pulley

REMACLEAN PUR-F3 / PUR-F4

Primary belt scraper system with a polyurethane blade and a spring lever tension unit for the cleaning of conveyor belt top covers at the head pulley (pulley diameters from 220 to 1600 mm).

- The polyurethane blade optimally adjusts to the belt surface and guarantees effective cleaning
- Long service life is achieved by using highly wear resistant polyurethane material
- Suitable for use with mechanical fasteners
- Easy installation and adjustment, the spring lever tension unit requires minimum maintenance
- Uniform and optimal contact pressure is easily set
- Suitable for abrasive and sticky materials as a primary cleaning system
- Can be used for shuttle belt operation and crowned pulleys
- PUR-F3 for pulley diameters from 220 mm
- PUR-F4 for pulley diameters from 500 mm
- Version for underground application available (ATEX)
- For belt speeds up to 4 m/s

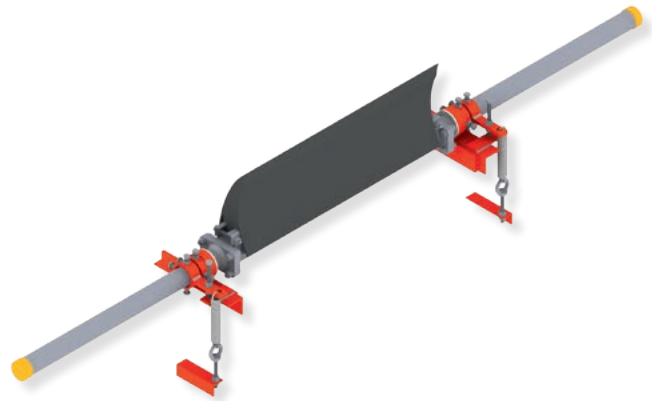

REMACLEAN PUR-F5

Primary belt scraper system with a blade consisting of polyurethane segments and a spring lever tension unit for the cleaning of conveyor belt top covers at the head pulley (pulley diameters from 320 mm).

- The polyurethane segments optimally adjust to the belt surface and guarantee effective cleaning (each segment has its own dynamic)
- Long service life is achieved by using highly wear resistant polyurethane material
- Suitable for use with mechanical fasteners
- Easy installation and adjustment, the spring lever tension unit requires minimum maintenance
- Polyurethane segments with snap closing
- Uniform and optimal contact pressure is easily set
- Suitable for abrasive and sticky materials as a primary cleaning system
- Suited for reverse operation and crowned pulleys
- For belt speeds up to 4 m/s

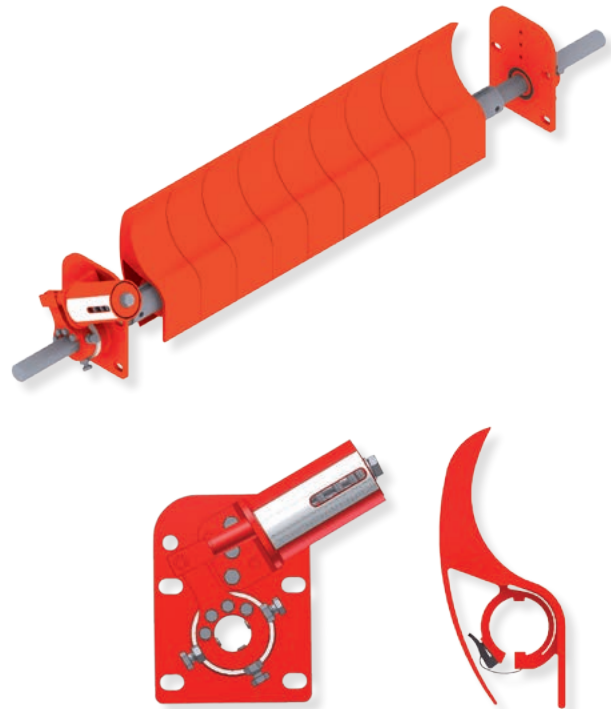

REMACLEAN U-SERIES – for use on belt

The belt cleaning systems of the REMA TIP TOP U Series are designed for cleaning of conveyor belt top covers at the return side of the conveyor. Combination with a primary scrapers system of the F Series is recommended to achieve optimal cleaning efficiency. The U Series provides various cleaning systems for almost any application. All systems utilize tungsten carbide blades for the cleaning of the belt. Systems with a single blade as well as individually supported tungsten carbide segments are available.

REMACLEAN HM-U1

REMACLEAN HM-U1 is a belt cleaning system for belt return side applications consisting of tungsten carbide segments and a torsion tension unit with spindle adjustment.

- Superior cleaning performance
- Long service life achieved by premium carbides
- Modular system consisting of support tube, carbide segments, support tube extensions and spindle-type tension units
- Constant and ideal contact pressure that is easy to adjust
- Flange connection for quick and easy installation/replacement
- Arbor kits can be mounted inside or outside the conveyor construction
- Damage of the belt edges is prevented by rounded outer carbide segments
- Can be upgraded for reverse operation
- Special version for temperatures up to 120° is optional
- For belt speeds up to 6.5 m/s

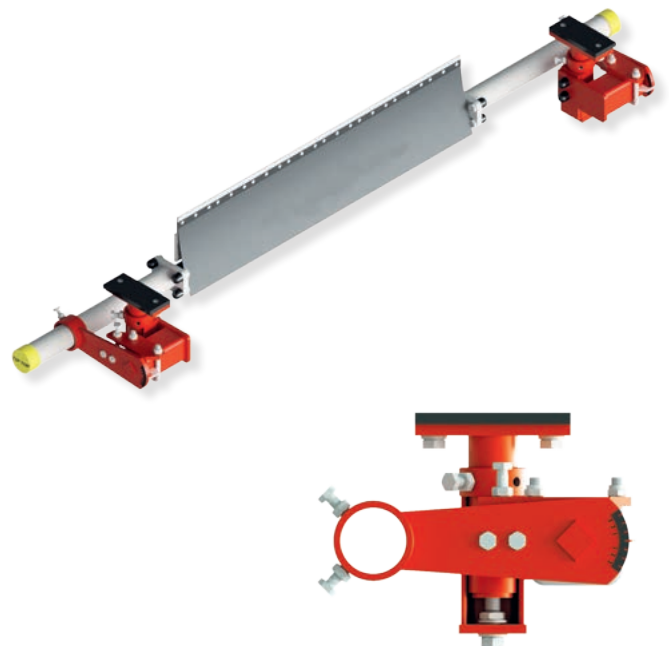

REMACLEAN HM-U2

REMACLEAN HM-U2 is a belt scraper system for belt return side applications with a tungsten carbide blade and a torsion tension unit with spindle adjustment.

- Excellent cleaning efficiency
- Long service life by using high quality tungsten carbides
- Modular system consisting of support tube, scraper blade, support tube extension and spindle kit with torsion pressure support
- Flange connection for easy and quick installation
- Spindle kits can be mounted inside or outside the conveyor construction
- Constant and ideal contact pressure can be easily adjusted
- Anti caking coating made of highly wear resistant REMATHAN ensures smooth material run off
- Belt friendly cleaning due to rounded edges of the outer blades
- Can be upgraded for reverse operation
- For belt speeds up to 6.5 m/s

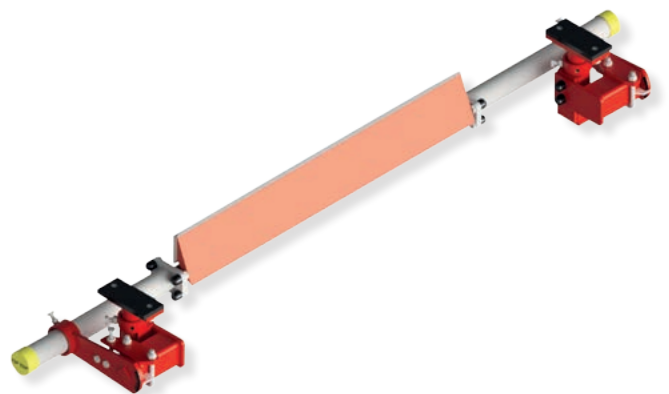

REMACLEAN U-SERIES – for use on belt

REMACLEAN HM-U3

REMACLEAN HM-U3 is a belt scraper system for belt return side applications with a tungsten carbide blade featuring a low installation height and tension unit INNOVATION.

- Universally applicable for many types of materials
- Excellent cleaning efficiency
- Long service life of the tungsten carbides due to highly wear resistant materials
- Belt friendly cleaning due to rounded edges of the blade
- Easy installation and adjustment of the scraper system
- Low installation space requirement
- Automatic system adjustment
- Tension unit INNOVATION with precise micro adjustment of the contact pressure
- Integrated pitch adjustment of the scraper blade
- REMA-REPCOAT SL anti-caking coating on the tungsten carbide blade
- Applicable for temperatures from -40°C to +130°C
- For belt speeds up to 4.0 m/s

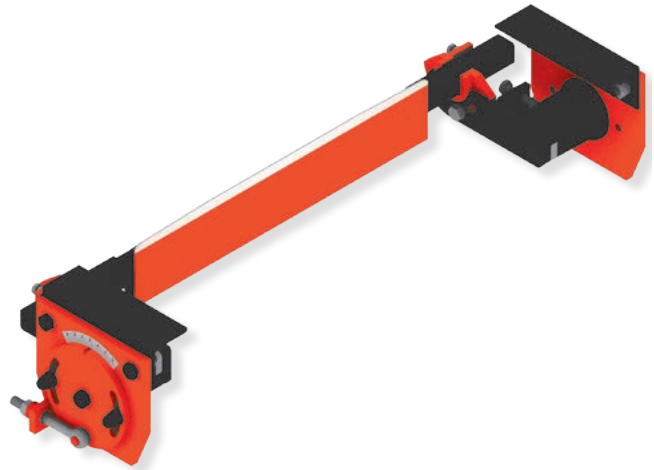

REMACLEAN HM-U4 / HM-U5

Belt cleaning system for belt return side applications with a "CONTOUR"-tungsten carbide blade and tension unit STANDARD or INNOVATION.

- Parabolic arc design of the scraper blade
- Perfect adaptability to the conveyor belt surface
- Excellent cleaning efficiency
- Long service life of the tungsten carbides
- Shock resistant design of the tungsten carbides
- Low installation space requirement
- Easy installation and adjustment of the scraper system
- Automatic adjustment of the system
- Integrated pitch adjustment of the scraper blade
- Multi layer corrosion protection coatings of the scraper blade
- For belt speeds up to 2.5 m/s

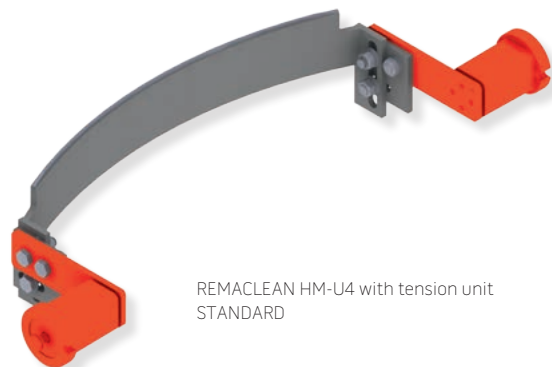

REMACLEAN HM-U4 with tension unit
STANDARD

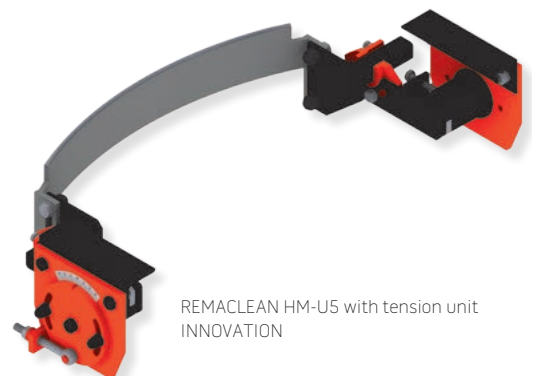

REMACLEAN HM-U5 with tension unit
INNOVATION

REMACLEAN U-SERIES – for use on belt

REMACLEAN HM-U6

REMACLEAN HM-U6 is a belt cleaning system for return side application with elastically mounted carbide segments and a torsion tension unit with spindle adjustment.

- Belt friendly cleaning produced by the sagging function of the carbide segments
- Segments are individually supported and can adjust in the moving direction of the belt
- Precise adjustment of the necessary contact pressure is achieved by the torsion tension unit
- Superior tungsten carbide blades ensure long service life
- Compact design
- Carbide segments with material run-off skirts
- Individually supported (rubber spring elements) carbide segments
- For belt speeds up to 2.5 m/s

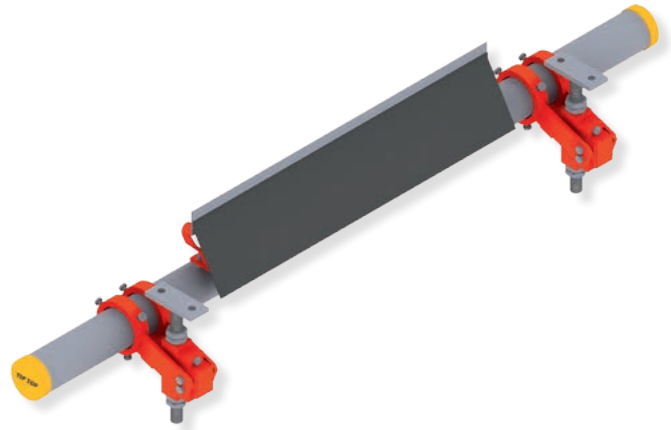

REMACLEAN HM-U7 / HM-U8

Belt cleaning system for belt return side applications with elastically supported tungsten carbide blades and a spindle-type tension unit.

- Belt friendly cleaning produced by the sagging function of the segment bars
- Individually supported blades that can rotate around their own axis
- Optimal adjustment to the conveyor belt surface
- Precise adjustment of the required contact pressure
- Top quality tungsten carbide blades provide long service life
- Compact design
- Tool free installation / exchange of segments
- Tungsten carbide blades in stainless steel design
- Combines the benefits of polyurethane and tungsten carbide
- Suitable for bulk material applications in all sectors of industry
- Special versions
MF for use with Mechanical Fasteners; special, shock resistant design of the carbide segments
V for use in underground applications (ATEX)
- REMACLEAN HM-U7 for belt speeds up to 2.5 m/s
- REMACLEAN HM-U8 for belt speeds up to 5,5 m/s

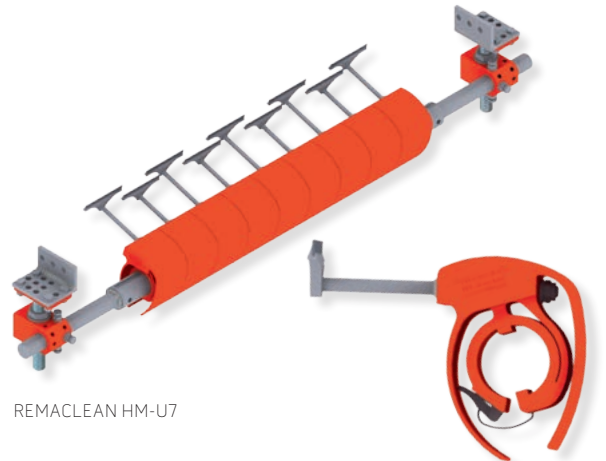

REMACLEAN HM-U7

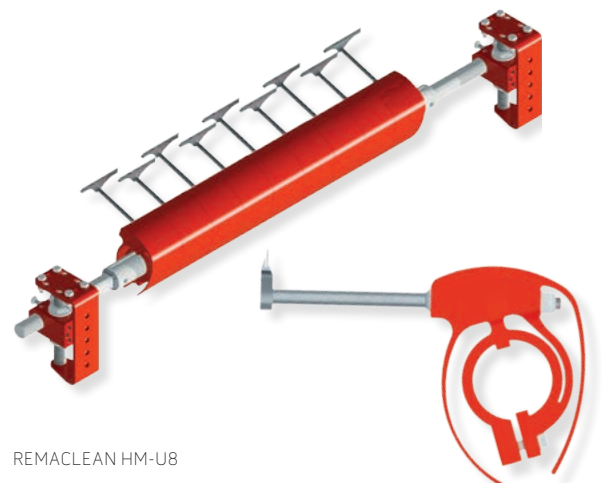

REMACLEAN HM-U8

REMACLEAN U-SERIES – for use on belt

REMACLEAN HM-U9

Belt cleaning system for return side application with elastically mounted carbide segments and a torsion tension unit with swinging arm.

- Belt friendly cleaning produced by the sagging function of the carbide segments
- Segments are individually supported and can adjust in the moving direction of the belt
- Precise adjustment of the necessary contact pressure is achieved by the torsion tension unit
- Superior tungsten carbide blades ensure long service life
- Compact design
- Carbide segments with material run-off skirts
- Individually supported (rubber spring elements) carbide segments
- For belt speeds up to 6.5 m/s

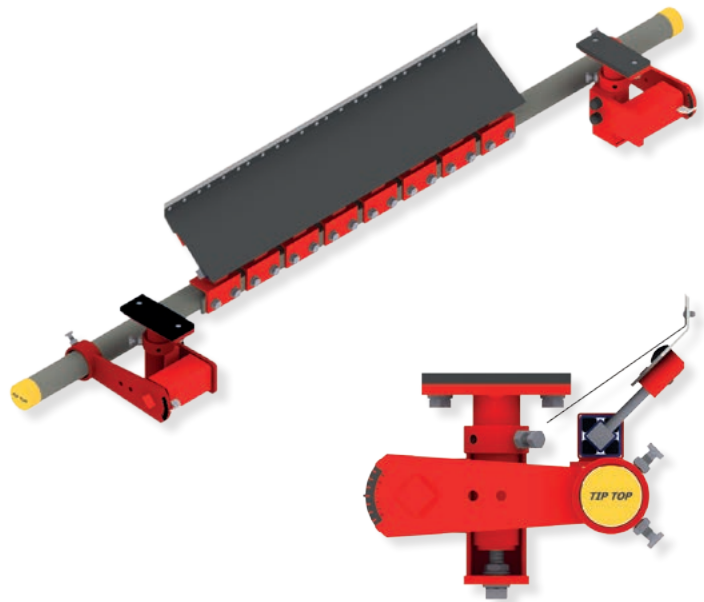

REMACLEAN HM-U10

Belt cleaning system for return side application with elastically mounted carbide segments and a torsion tension unit without swinging arm.

- Belt friendly cleaning produced by the sagging function of the carbide segments
- Segments are individually supported and can adjust in the moving direction of the belt
- Precise adjustment of the necessary contact pressure is achieved by the torsion tension unit
- Superior tungsten carbide blades ensure long service life
- Very compact design
- Carbide segments with material run-off skirts
- Individually supported (rubber spring elements) carbide segments
- For belt speeds up to 6.5 m/s

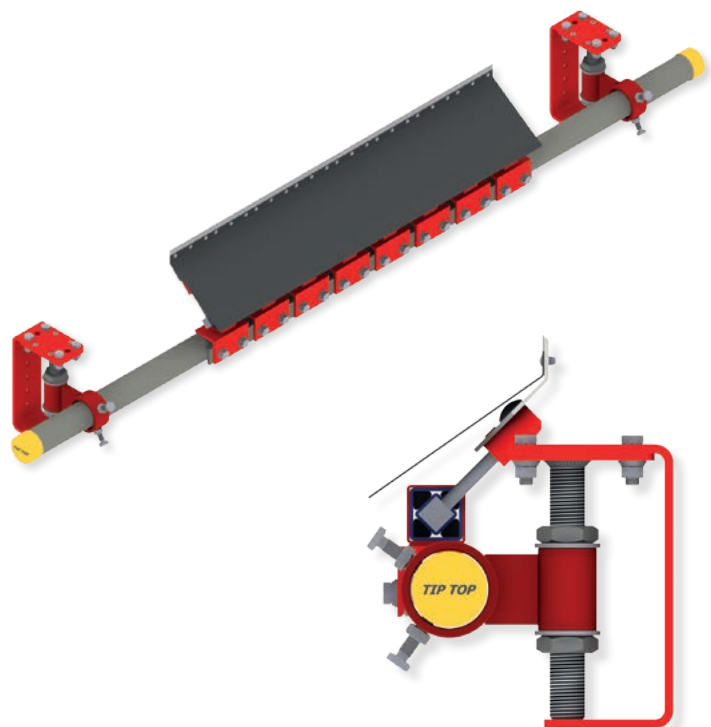

REMACLEAN U-SERIES – for use on belt

REMACLEAN HM-U11 R

Belt cleaning system for return side application with elastically mounted carbide segments and a torsion tension unit suited for reverse operation. High cleaning efficiency and long service life through high-quality of the carbides. Good adaptability to the conveyor belt through flexible mounted blade segments.

Universally applicable to many types of materials such as sand, gravel, hard coal, lignite, ores, sinter, cement, clay, conditioned refuse and gypsum.

- Belt friendly cleaning achieved by the sagging function of the blade segments
- The tungsten carbide segments manufactured from stainless steel are individually supported, can adapt dynamically in the running direction of the belt and move 180° on its own axis
- Modular system consisting of a robust system suspension tube, carbide blades, foot made from soft Polyurethane and a spindle mounting system
- robust sliding deflectors made from polyethylene for the highest loads
- Consistent and ideal contact pressure, which is easily adjustable
- Low-maintenance
- System carrier is protected with sliding aprons of the PUR foot
- Version with PUR segment foot with screw mounting available
- Particularly suited for reverse operation
- For belt widths up to 2 000 mm
- Designed for service temperatures from -40 °C to +70 °C and belt speeds up to 6.5 m/s

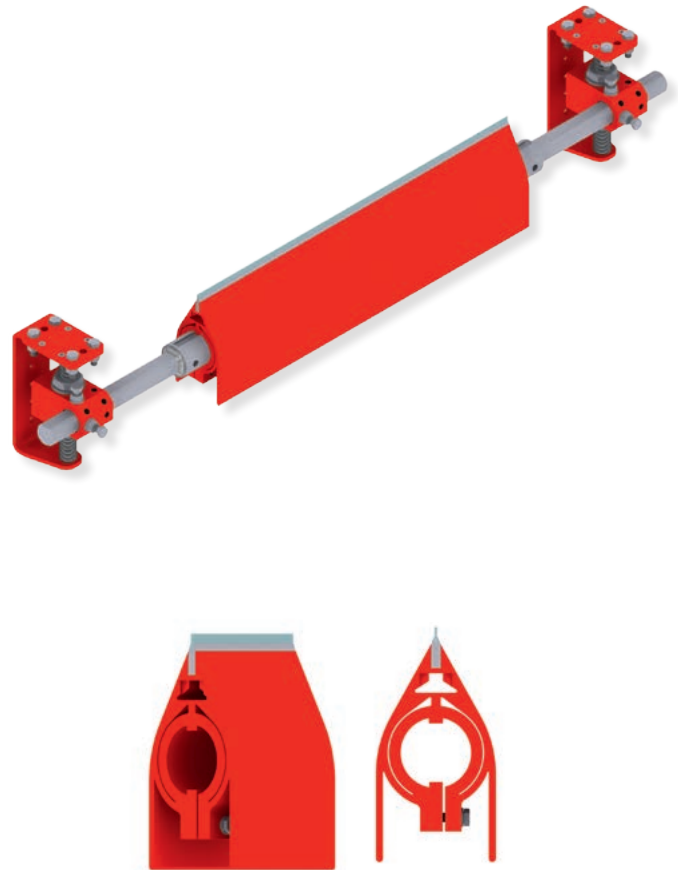

BELT CLEANING BRUSHES

There are applications where static belt cleaning systems do not deliver satisfying cleaning results. Our belt cleaning brushes are the ideal solution for these special applications.

REMACLEAN GRB

REMACLEAN GRB is a belt cleaning system with electrically rubber brush for the cleaning of sticky and powdery materials from conveyor belt top covers.

- Belt cleaning brush with direct drive from electric motor
- Ideal for cleaning of fine, powdery and also sticky materials
- Ideal in combination with a primary belt cleaning system (especially when having wet materials)
- High flexibility of the rubber bristles ensure belt friendly cleaning
- Self cleaning
- Available for ATEX applications
- Available for food applications as well as oil resistant version
- For belt speeds up to 2.5 m/s

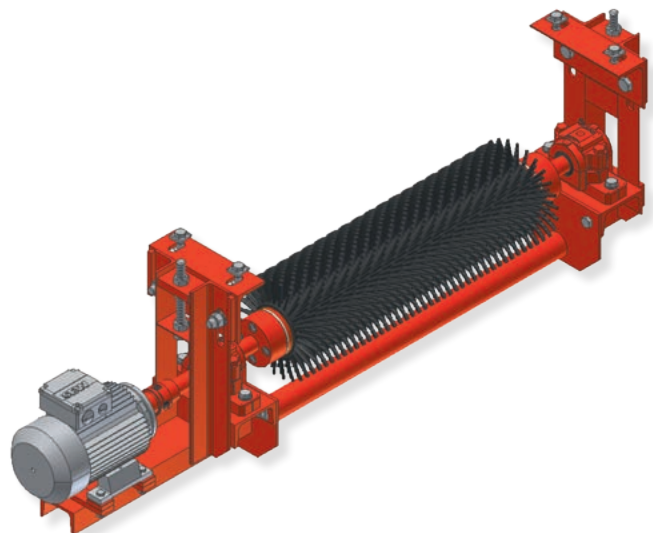

BELT CLEANING BRUSHES

REMACLEAN TMB

REMACLEAN TMB is an electrically driven conveyor belt cleaning system with a plastic brush designed for the cleaning of belts that convey dry material at operating temperatures up to 80° C.

- Belt friendly cleaning
- Cleaning of dry and wettish materials
- Easy and quick adjustment with the spindle system
- Availability of various brush types for different requirements
- Compact design due to drum motor
- Pivot mechanism for optimum positioning
- For belt speeds up to 6.5 m/s



REMACLEAN SGB

REMACLEAN SGB is a belt cleaning system with electrically driven rubber brush for cleaning of the top cover of incline conveyors, especially chevron belts.

- Unique cleaning of incline conveyor belts with cleats up to 24 mm
- Rotation in opposite direction to belt
- Long service life by using high quality rubber compounds (REMALINE 70)
- Motors for ATEX applications available on request
- For belt speeds up to 2.5 m/s

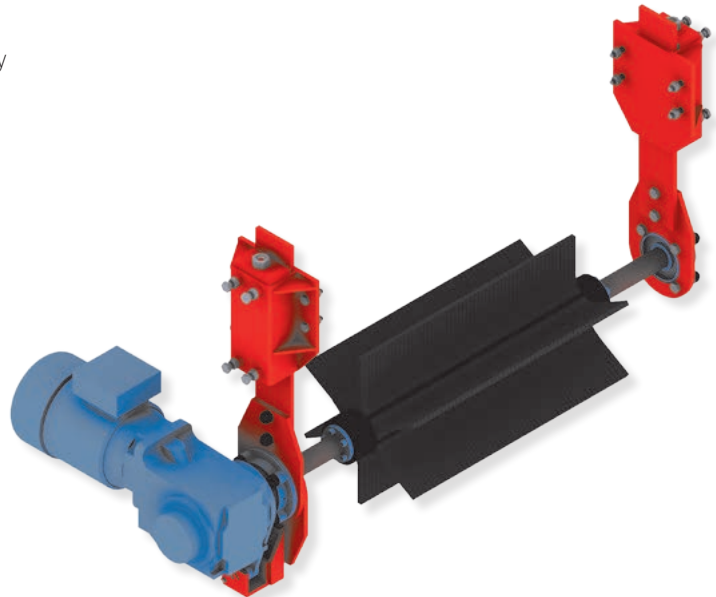

INNER BELT SCRAPER SYSTEMS

Inner belt scrapers ensure that no material gets between belt and pulley and therefore prevents major damage to the belt as well as the pulley.

REMACLEAN RB-IGD – Diagonal scraper

- Diagonal scraper for return side applications at the running side to protect the pulley from material
- A scraper rubber made of REMACLEAN CAB is mounted in the frame
- The required contact pressure is achieved by the spindle-type tension unit
- Easy installation, adjustment and maintenance of the system
- All steel parts are coated with COROPUR (red)
- Suited for reverse operation
- Available for underground applications (ATEX).



REMACLEAN RB-IGP – V-Plough scraper

- V-Plough scraper system for return side applications at the running side to protect the pulley from material
- Frame with integrated idlers and scraper plough (rubber bar made of REMACLEAN CAB)
- The frame construction levels off the belt and thus guarantees optimum alignment of the scraper and ensures efficient cleaning
- The required contact pressure is created by the weight of the system
- An auxiliary wheel mounted on the scraper prevents contact of the steel frame with the belt surface after the rubber bar is worn out
- All steel parts are coated with COROPUR (red)
- Available for underground applications (ATEX).

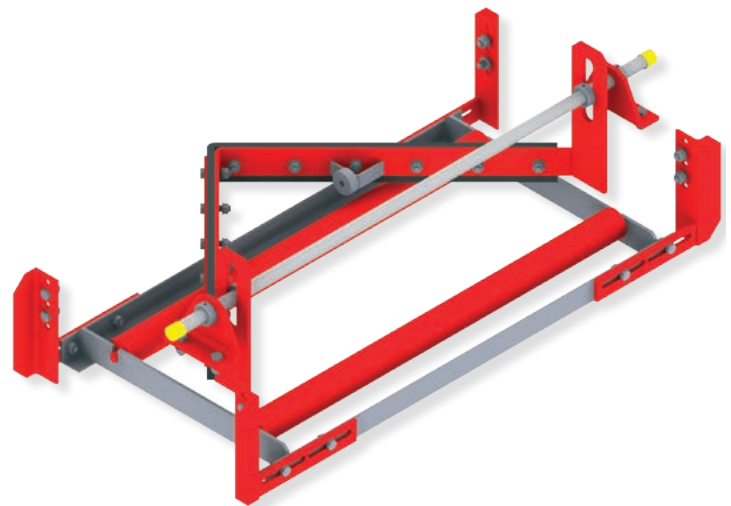

OVERVIEW: F-Series

REMACLEAN – belt cleaning systems for use on pulley



Type	HM-F1	HM-F2	PUR-F3	PUR-F4	PUR-F5
Belt width (mm)	800-2600	400-2000	400-1600	800-2000	800-1600
Type of cleaning system	V, H	V, H	V	V	V, H
For belt speeds up to (m/s)	6.5	4.5	4	4	4
Suited for reverse operation	yes	yes	yes	yes	yes
Blade type	S	S	D	D	S
Blade material	HM	HM	PUR	PUR	PUR
Max. operating temperature (°C)	60	120	60	60	60
ATEX version available	no	no	yes	yes	yes
Suitable for mechanical fasteners	no	no	yes	yes	yes
Available for food industry	no	no	no	no	yes
Suitable for oily and greasy materials	3	3	2	2	2
Sand/gravel (dry)	1	1	1	1	1
Sand/gravel (wet)	1	1	1	1	1
Coal (raw)	1	1	1	1	1
Lignite/tailing	1	1	1	1	1
Ore	1	1	2	2	2
Sinter	1	1	2	2	2
Clay	3	1	2	2	2
Cement	1	1	1	1	1
Gypsum	3	3	2	2	3
Waste	3	3	2	2	3

V = Pre-cleaner, H = Main cleaner, G = Basic cleaning, F = Fine cleaning, S = Segments, D = Seamless blade, HM = Tungsten carbide, PUR = Polyurethane
1 = recommendable, 2 = limited suitability, 3 = not recommendable

The recommendations listed as examples of the use of the products are based on experience gained in technical applications but are not an assurance of their suitability for specific application areas. These recommendations do not obviate the need for the user to check this. In individual cases, we recommend that technical application advice is taken – experienced REMA TIP TOP specialists are available for this purpose.

OVERVIEW: U-Series

REMACLEAN – belt cleaning systems for use on belt

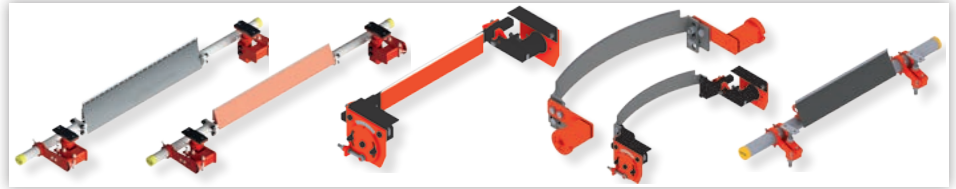

Type	HM-U1	HM-U2	HM-U3	HM-U4/-U5	HM-U6
Belt width (mm)	400-2400	500-1400	400-1200	500-1200	500-2000
Type of cleaning system	V, H	V, H	V, H	V, F	F
For belt speeds up to (m/s)	4.5	4.5	4.0	2.5	2.5
Suited for reverse operation	yes*	yes*	yes*	no	no
Blade type	D	D	D	D	S
Blade material	HM	HM	HM	HM	HM
Max. operating temperature (°C)	120**	60	120**	60	60
ATEX version available	no	no	no	no	no
Suitable for mechanical fasteners	no	no	no	no	no
Available for food industry	yes**	no	no	no	no
Suitable for oily and greasy materials	1	2	2	2	3
Sand/gravel (dry)	1	1	1	2-3	1
Sand/gravel (wet)	1	1	1	1-2	1
Coal (raw)	1	1	1	1-2	1
Lignite/tailling	1	1	1	2-3	1
Ore	1	1	1	2-3	1
Sinter	1	1	1	2-3	1-2
Clay	1	1	1	2-3	1
Cement	1	1	1	1-2	1
Gypsum	1-2	1-2	1-2	2-3	2-3
Waste	2	1	1	1	2

V = Precleaner, H = Main cleaner, G = Basic cleaning, F = Fine cleaning, S = Segments, D = Seamless blade, HM = Tungsten carbide
* = with reversing stop ** = as special version 1 = recommendable, 2 = limited suitability, 3 = not recommendable

The recommendations listed as examples of the use of the products are based on experience gained in technical applications but are not an assurance of their suitability for specific application areas. These recommendations do not obviate the need for the user to check this. In individual cases, we recommend that technical application advice is taken – experienced REMA TIP TOP specialists are available for this purpose.

OVERVIEW: U-Series

REMACLEAN – belt cleaning systems for use on belt



Type	HM-U7	HM-U8	HM-U9	HM-U10	HM-U11 R
Belt width (mm)	400-1400	800-2000	650-2000	400-2200	400-2000
Type of cleaning system	F	F	F	F	F
For belt speeds up to (m/s)	2.5	5.5	6.5	6.5	6.5
Suited for reverse operation	no	no	no	no	yes
Blade type	S	S	S	S	S
Blade material	HM	HM	HM	HM	HM
Max. operating temperature (°C)	60	60	70	70	-40 +70
ATEX version available	yes**	yes**	no	no	yes
Suitable for mechanical fasteners	yes**	yes**	no	no	no
Available for food industry	yes	yes	no	no	yes
Suitable for oily and greasy materials	2	2	3	3	2
Sand/gravel (dry)	1	1	2	2	1
Sand/gravel (wet)	1	1	1	1	1
Coal (raw)	1	1	2	2	1
Lignite/tailing	1	1	3	3	2
Ore	1	1	2	2	1
Sinter	1	1	2	2	1
Clay	1	1	3	3	2
Cement	1	1	1	1	1
Gypsum	2-3	2-3	3	3	2-3
Waste	2	2	3	3	2-3

V = Pre-cleaner, H = Main cleaner, G = Basic cleaning, F = Fine cleaning, S = Segments, D = Seamless blade, HM = Tungsten carbide
 * = with reversing stop ** = as special version 1 = recommendable, 2 = limited suitability, 3 = not recommendable

The recommendations listed as examples of the use of the products are based on experience gained in technical applications but are not an assurance of their suitability for specific application areas. These recommendations do not obviate the need for the user to check this. In individual cases, we recommend that technical application advice is taken – experienced REMA TIP TOP specialists are available for this purpose.

OVERVIEW: Scraper bars

REMACLEAN – belt cleaning systems for use on belt



Type	KWA	M	C	PUR
Belt width (mm)	500-1800	500-1600	500-1600	500-1600
Type of cleaning system	V, H	V, H	V, H	V, H
For belt speeds up to (m/s)	3.5	3.5	3.5	3.5
Suited for reverse operation	no	yes	yes	yes
Blade type	D	D	D	D
Blade material	Rubber	Rubbermetal	Rubberceramic	PUR
Max. operating temperature (°C)	70	70	70	70
ATEX version available	yes	no	no	yes
Suitable for mechanical fasteners	yes	no	no	yes
Available for food industry	yes	no	no	no
Suitable for oily and greasy materials	1	3	3	2
Sand/gravel (dry)	3	2	3	3
Sand/gravel (wet)	2	2	3	2
Coal (raw)	2	2	2	2
Lignite/tailing	3	2	2	2
Ore	3	2	3	2
Sinter	3	2	3	3
Clay	2	2	2	2
Cement	2	2	2	1
Gypsum	3	2	2	2
Waste	2	1	1	1

V = Precleaner, H = Main cleaner, G = Basic cleaning, F = Fine cleaning, S = Segments, D = Seamless blade, PUR = Polyurethane
1 = recommendable, 2 = limited suitability, 3 = not recommendable

The recommendations listed as examples of the use of the products are based on experience gained in technical applications but are not an assurance of their suitability for specific application areas. These recommendations do not obviate the need for the user to check this. In individual cases, we recommend that technical application advice is taken – experienced REMA TIP TOP specialists are available for this purpose.

OVERVIEW: Belt cleaning brushes

REMACLEAN – belt cleaning systems for use on belt

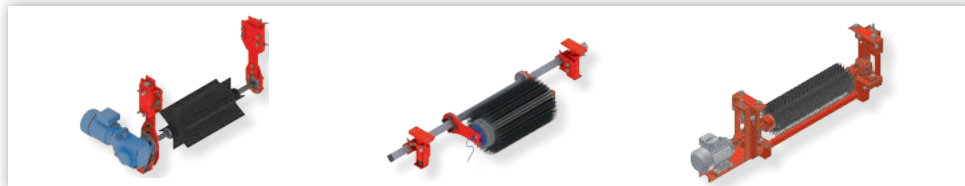

Type	SGB	TMB	GRB
Belt width (mm)	400-1400	400-1400	400-2000
Type of cleaning system	H	F	F
For belt speeds up to (m/s)	2.5	6.5	2.5
Suited for reverse operation	yes*	yes	yes
Brush material	Rubber	Plastic	Rubber
Max. operating temperature (°C)	70	80	70
ATEX version available	no	no	yes
Suitable for mechanical fasteners	yes	no	no
Available for food industry	no	yes	yes
Suitable for oily and greasy materials	2	3	2
Sand/gravel (dry)	1	2	1
Sand/gravel (wet)	1	3	1
Coal (raw)	1	3	1
Lignite/tailing	1	3	2
Ore	1	3	2
Sinter	2	3	3
Clay	2-3	-	-
Cement	1	2	1
Gypsum	3	-	-
Waste	1	2-3	2

V = Pre-cleaner, H = Main cleaner, G = Basic cleaning, F = Fine cleaning, S = Segments, D = Seamless blade, HM = Tungsten carbide, PUR = Polyurethane
 1 = recommendable, 2 = limited suitability, 3 = not recommendable
 * with rotation speed switchover
 EX motors are available upon request.

OVERVIEW: Inner belt scrapers

REMACLEAN – return side scrapers

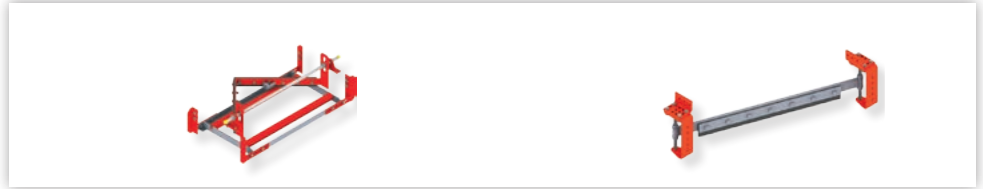

Type	RB-IGP	RB-IGD
Belt width (mm)	500-1600	500-1600
Type of cleaning system	G	G
For belt speeds up to (m/s)	3.5	3.5
Suited for reverse operation	no	yes
Blade type	D	D
Blade material	Rubber	Rubber
Max. operating temperature (°C)	70	70
ATEX version available	yes	yes
Suitable for mechanical fasteners	yes	yes
Available for food industry	yes	yes
Suitable for oily and greasy materials	1	1
Sand/gravel (dry)	1	1
Sand/gravel (wet)	1	1
Coal (raw)	1	1
Lignite/tailing	1	1
Ore	1	1
Sinter	1	1
Clay	1	1
Cement	1	1
Gypsum	1	1
Waste	1	1

V = Precleaner, H = Main cleaner, G = Basic cleaning, F = Fine cleaning, S = Segments, D = Seamless blade
1 = recommendable, 2 = limited suitability, 3 = not recommendable

The recommendations listed as examples of the use of the products are based on experience gained in technical applications but are not an assurance of their suitability for specific application areas. These recommendations do not obviate the need for the user to check this. In individual cases, we recommend that technical application advice is taken – experienced REMA TIP TOP specialists are available for this purpose.

QUESTIONNAIRE:
REMACLEAN Belt Cleaning System

Company _____

Information about conveyor equipment:

Belt designation: _____ Type/make: _____ Strenth (mm): _____

Belt width (mm): _____ Distance between pulleys (m): _____ Belt speedt (m/s): _____

Belt surface: new used/smooth damaged heavily damaged

Shuttle belt conveyor: yes no

Belt splice: cold vulk. hot vulk. mechanical

Operating time: _____ hours per day _____ days per week

Temperature at the site where the belt cleaning system is to be used: _____ °C

Pulley diameter _____ mm

Pulley shape:: cylindric crowned lagging thicknesses (mm): _____

Pulley lagging condition: new evenly used damaged heavily damaged

Remarks: _____

Material conveyed _____ Lump size (mm): _____

Moisture content _____% Tends to dry or harden: yes no

Quartz content: yes _____% no

Sticky admixture content: _____

Installed cleaning system:

Manufacturer: _____ Type: _____

Estimate of cleaning performance: _____

Remarks (Please enclose photos): _____

Information prepared:

 Place and date Name Signature

New REMACLEAN cleaning system recommended:

Pre-cleaner: _____ Ref. No.: _____

Main cleaner: _____ Ref. No.: _____

Remarks: _____

Recommendation prepared:

 Place and date Name Signature



Your local contact



// ONE BRAND // ONE SOURCE // ONE SYSTEM

- // SERVICE
- // MATERIAL PROCESSING
- // SURFACE PROTECTION
- // AUTOMOTIVE

REMA TIP TOP AG
Gruber Strasse 65 · 85586 Poing / Germany
Phone: +49 8121 707-100
Fax: +49 8121 707-10 222
info@tiptop.de
www.rema-tiptop.com



582 0081 - XII.16 Printed in Germany

